

Article type:
Original Research

1, 2, 3, 4 Universitas Negeri Malang, Indonesia.
1 Universitas Muhammadiyah Surabaya, Indonesia.

Corresponding author email address:
naili.saida.2201139@students.um.ac.id



Article history:

Received 11 Oct 2025
Revised 27 Dec 2025
Accepted 30 Jan 2026
Published online 01 Mar 2026

How to cite this article:

Sa'ida, N., Hanurawan, F., Farida, I. A., & Chusniyah, T. (2026). Cultural Adaptation and Factorial Validation of the General Campus Climate Scale (GCCS) in Indonesian Higher Education. *International Journal of Body, Mind and Culture*, 13(3), 85-94.



© 2025 the authors. This is an open-access article under the terms of the Creative Commons Attribution-NonCommercial 4.0 International (CC BY-NC 4.0) License.

Cultural Adaptation and Factorial Validation of the General Campus Climate Scale (GCCS) in Indonesian Higher Education

Naili. Sa'ida^{1*}, Fattah Hanurawan², Ika Andriani. Farida³, Tutut. Chusniyah⁴

ABSTRACT

Objective: Campus climate refers to students' perceptions of their academic environment, including interactions with lecturers, staff, and peers, which may influence cognitive, emotional, psychological, and attitudinal outcomes. The General Campus Climate Scale (GCCS) is a widely used instrument for assessing this construct; however, its application across different cultural contexts requires systematic adaptation and empirical evaluation of its psychometric properties. This study aimed to adapt the GCCS for Indonesian higher education contexts culturally and to examine its factorial validity.

Methods and Materials: The adaptation process followed the International Test Commission (ITC) guidelines, including translation, synthesis, expert review, readability testing, and layout revision. Data were collected from Indonesian university students and analyzed using confirmatory factor analysis (CFA) with AMOS 22 to test a two-dimensional model of campus climate (general campus climate and academic climate).

Findings: All items had standardized factor loadings above 0.50, supporting their contribution to the proposed factors. Several goodness-of-fit indices indicated an acceptable but not optimal model fit ($\chi^2 p < .001$; RMSEA = 0.095), suggesting a borderline to moderate level of fit.

Conclusion: These findings provide preliminary support for the factorial structure of the Indonesian version of the GCCS; however, other aspects of validity, such as criterion-related validity, measurement invariance, and test-retest reliability, were not examined and should be addressed in future research. Overall, the adapted GCCS may serve as a useful instrument for assessing campus climate in Indonesian higher education, with further validation warranted.

Keywords: Campus climate, confirmatory factor analysis, Indonesian culture.

Introduction

Campus climate refers to the overall atmosphere perceived by members of a higher education institution, including students, faculty, educational staff, parents, and the surrounding community (Maxwell et al., 2017). In higher education settings, the term *campus climate* is commonly used to describe the cultural, social, academic, and physical characteristics of the university environment that shape daily interactions and experiences. As such, campus climate reflects not only institutional structures but also shared perceptions, values, and norms that emerge through social relations and organizational practices within the campus community.

Campus climate is an important factor that determines educational success (Voight & Nation, 2016) and student success (Chirkina & Khavenson, 2018; Maxwell et al., 2017). Campus climate affects not only academic success but also social skills, self-esteem, and the emotional and psychological well-being of individuals (Chirkina & Khavenson, 2018). In addition, campus climate plays a role in students' adaptive psychosocial adjustment, mental health, and self-esteem, and influences levels of bullying, aggression, and delinquency (Cohen, 2012; Maxwell et al., 2017).

Conceptually, campus climate is often understood as an atmosphere that can either facilitate or hinder students' cognitive, moral, emotional, and psychological growth (Okendo et al., 2014). According to DeWitt (2017), a positive campus climate is characterized by inclusivity, mutual respect, and meaningful participation among all members of the academic community. Furthermore, Wang & Degol (2016) conceptualize campus climate as encompassing environmental quality, community relationships, safety, and institutional practices that collectively influence students' cognitive, behavioral, and psychological development. These perspectives underscore the multidimensional nature of campus climate as both a social and institutional construct (Cohen, 2012).

This is in line with what was stated by Reid & Radhakrishnan (2003), who stated that campus climate is the atmosphere experienced by students related to their academic experiences, such as treatment from lecturers, staff, and friends, which will affect cognitive, emotional, psychological, attitudinal, and value aspects. (Reid &

Radhakrishnan, 2003) stated that campus climate has four aspects, namely: 1) General campus climate, which is defined as the campus atmosphere in creating the climate, including the involvement of students, lecturers, and staff; 2) Lecturers, namely lecturers who are responsible for providing learning in higher education, creating an academic atmosphere that is conducive to academic development, and providing support and direction to students; 3) Perception of seriousness, namely the lecturer's view of the seriousness of his students, which is felt by lecturers, students, or colleagues, for example lecturers who view students as serious figures; and 4) Perception of respect, namely the social and intellectual respect felt by students, such as the students' respect for lecturers who encourage them to make positive decisions.

from a scale developed by Johns Hopkins University, consisting of three aspects, namely engagement, safety, and environment. The MDS3 scale has 18 statement items measured using a four-choice Likert scale. For items with positive values (favorable), the answer choices used are 4 (Strongly Agree), 3 (Agree), 2 (Disagree), and 1 (Strongly Disagree). Meanwhile, for items with negative values (unfavorable), the answer choices are reversed, namely 1 (Strongly Agree), 2 (Agree), 3 (Disagree), and 4 (Strongly Disagree). However, some criticisms have been directed at the weaknesses of the MDS3 scale, including: (1) Limitations in measurement, because it uses an ordinal approach, so that respondents cannot make in-depth quantitative comparisons between individuals, although they can rank their level of agreement. This makes it difficult to interpret the results, because not all differences in scores reflect practically significant differences. (2) Ambiguity of response, namely the possibility of differences in respondents' understanding of the statements asked, which can lead to inconsistent interpretations, resulting in inconsistent and difficult-to-analyze data. (3) Limitations in capturing psychological aspects; although the MDS3 measures involvement, safety, and environment, this instrument may not fully capture the psychological or emotional nuances of students that affect their experiences on campus, such as academic pressure or interpersonal relationships that are not effectively represented.

In addition to the measuring instrument developed by Johns Hopkins, Gloria and Robinson (1998) designed the

University Environment Scale (UES). This measuring instrument was developed in 1996 by Gloria & Kurpius (1996) to assess students' perceptions of the university environment. The UES comprises 14 items that assess various aspects of the university environment, including faculty support, social interactions, and the overall campus atmosphere. Students are asked to provide ratings using a seven-point Likert scale, ranging from "not at all" to "very true". This scale was originally developed to identify and understand factors that influence the academic success of Chicano/a students.

Research shows that perceptions of the university environment can be an important predictor of students' decisions to persist at a higher education institution (Sury, 2016). The UES has been tested for validity and reliability, and has demonstrated high internal consistency. For example, research results show that this scale has a high Cronbach's alpha coefficient, indicating a strong internal consistency among items (Thacker, 2007). Although originally designed for Chicano/a students, the UES has been used in a variety of contexts to assess the experiences of students from diverse ethnic and cultural backgrounds in the university environment. Examples of statements in the UES include, "Faculty are available to help outside of class" and "The university feels like a cold and uncaring place to me," which reflect various aspects of students' experiences on campus (Sury, 2016).

The weaknesses of the University Environment Scale (UES) include: (1) Limited validity and reliability. However, it has been validated; it is possible that this instrument does not fully capture the experiences of all student groups, especially those from different cultural backgrounds, which may reduce the validity of the survey results across various university contexts. (2) The UES focuses more on aspects of the academic and social environment, but may not take into account external factors such as economic conditions or broader educational policies, which can also significantly affect student experiences. (3) The UES requires adaptation to local or cultural contexts to be more relevant and accurate. Still, these adjustments are not always applied across various universities (Beasley & McClain, 2021).

Furthermore, campus climate measurement was also developed by Reid & Radhakrishnan (2003) through the General Campus Climate Scales (GCC). The GCC scale has two dimensions, namely General Campus Climate and Academic Climate, each of which consists of aspects such

as Instructor, Perceptions of Seriousness, and Perceptions of Respect. This scale uses seven alternative answers, ranging from 1 (strongly agree) to 7 (strongly disagree). The GCC aims to explore how students' perceptions of academic and racial climate impact their experiences at university. The scale includes measures of how students feel they are treated by faculty as well as their interactions with peers and the campus environment in general. The GCC comprises a series of items that reflect various dimensions of students' experiences, including comfort with interacting with faculty and perceptions of how fellow students treat them. This instrument uses a Likert scale format to measure respondents' level of agreement or disagreement with the statements. The GCC demonstrated good reliability, with Cronbach's alpha coefficients ranging from 0.70 to 0.85, indicating adequate internal consistency. In addition, the GCC also includes elements that measure students' experiences with racial issues, such as racial insensitivity from other students and perceptions of the interracial atmosphere on campus. This is important to understand the extent to which racial factors may influence the overall campus climate.

This study focuses exclusively on the General Campus Climate dimension of the GCC. This decision is theoretically grounded in the study's objective of assessing students' overall perceptions of the social and interpersonal campus environment, rather than pedagogical or instructional processes, which are more closely aligned with academic climate. By limiting the scope to General Campus Climate, the study seeks to maintain conceptual clarity and to avoid overlap between general environmental perceptions and academic constructs. The distinction between general campus climate and academic climate is therefore explicitly maintained throughout the study.

Although campus climate has been extensively examined in international research, studies focusing on the cultural adaptation and psychometric evaluation of campus climate instruments in the Indonesian higher education context remain limited. While research addressing related constructs may exist, published studies that systematically adapt and test the factorial structure of the General Campus Climate Scale using confirmatory methods in Indonesia appear to be scarce. Consequently, the present study aims to adapt the

General Campus Climate dimension of the GCC to the Indonesian cultural context and to examine its factorial validity using Confirmatory Factor Analysis (CFA) as an initial step toward establishing a psychometrically sound instrument for assessing campus climate in Indonesian higher education.

Methods and Materials

Study Design

This study employed a quantitative survey design to adapt the General Campus Climate Scale (GCC) to the Indonesian cultural context. Data were collected using a self-report questionnaire administered online via Google Forms. The study was conducted at several Muhammadiyah universities in East Java, Indonesia. A total of 200 undergraduate students aged 18 to 25 years participated in the study. Participants were enrolled in different study programs and year levels; however, detailed demographic distributions (e.g., gender, program of study, and year of enrollment) were not systematically recorded and therefore are not reported in this study. As a result, the sample's representativeness of the broader Indonesian higher education population cannot be fully established. In addition, because the participants were drawn exclusively from Muhammadiyah universities, which are characterized by a specific religious and organizational culture, the findings may reflect contextual characteristics unique to these institutions. They may not be directly generalizable to other types of universities in Indonesia.

Sampling Procedure

The sampling technique was initially conceptualized as a multistage random sampling approach. At the institutional level, Muhammadiyah universities in East Java were selected as the research sites. Within these institutions, student groups were approached through available academic networks. In practice, questionnaire links and QR codes were distributed to prospective participants via WhatsApp after an initial screening for eligibility criteria (i.e., undergraduate status and age range). Due to the reliance on online distribution and voluntary participation, the randomization process was limited at the individual level. Consequently, the sampling procedure should be interpreted as partially randomized rather than fully probabilistic. This

limitation is acknowledged as a constraint of the study design.

Instrument

The instrument adapted in this study was the General Campus Climate Scale (GCC) developed by Reid & Radhakrishnan (2003). The original GCC consists of two dimensions: *General Campus Climate* and *Academic Climate*. The General Campus Climate dimension reflects students' overall perceptions of the campus social environment, whereas the Academic Climate dimension includes perceptions of instructors, seriousness, and respect in academic interactions. In line with the objectives of the present study, the adaptation focused primarily on examining the GCC's factorial structure in the Indonesian context.

Translation and Cultural Adaptation Procedure

The translation and adaptation process followed the *ITC Guidelines for Translating and Adapting Tests* (Commission, 2019), which provide a comprehensive framework covering test development, implementation, and documentation. The adaptation process consisted of the following stages:

- 1) Precondition Stage, Permission to adapt the GCC into Indonesian was obtained via email correspondence with the second author of the original scale, Prof. Phanikiran Radhakrishnan. The original instrument was sourced from the article "*Race Matters: The Relation Between Race and General Campus Climate*" (Reid & Radhakrishnan, 2003).
- 2) Test Development Stage, The original English version of the GCC was independently translated into Indonesian by two certified translators affiliated with a university language center. Both translators were fluent in English and Indonesian and had experience in academic translation.
- 3) Synthesis Stage, the two translated versions were compared and discussed jointly by the translators and the researcher to resolve discrepancies and achieve semantic equivalence. This process resulted in a synthesized Indonesian draft of the GCC.
- 4) Expert Review Stage, the synthesized draft was reviewed by a subject-matter expert with a background in educational psychology and psychometric assessment. The review focused on conceptual equivalence, clarity of wording, and cultural appropriateness. Minor revisions were made to improve clarity and ensure consistency

with the original construct definitions, although no items were removed at this stage.

5) **Readability Testing Stage**, The Indonesian version of the GCC was pilot-tested on a small group of undergraduate students to assess clarity, comprehensibility, and interpretability of instructions and items. Feedback from participants indicated that the items were generally understandable; however, no quantitative pilot data were analyzed, and the pilot sample size was limited. Therefore, this stage was used primarily for qualitative refinement rather than formal psychometric evaluation.

6) **Format Arrangement Stage**, based on feedback from the expert review and readability testing, the layout of the scale, including instructions and item presentation, was revised to improve readability and ease of response before full data collection.

Response Scale Modification

In the present study, the GCC response format was modified from the original seven-point Likert scale to a four-point Likert scale ranging from 1 (*strongly disagree*) to 4 (*strongly agree*). This modification was intended to reduce neutral responding and to facilitate clearer response choices for participants. However, this change represents a substantial modification to the original instrument and may affect scale sensitivity and the functioning of response categories. The implications of collapsing response categories were not empirically examined in this study, nor were threshold or category functioning analyses conducted. This limitation is

acknowledged and should be addressed in future validation studies.

Data Analysis

Data analysis was conducted using AMOS version 22. Confirmatory Factor Analysis (CFA) was employed to examine whether the observed indicators adequately represented the latent constructs of the Indonesian version of the GCC. Model evaluation followed commonly recommended criteria, including model convergence and acceptable parameter estimates, goodness-of-fit indices, and the significance of parameter estimates. Although measurement invariance was initially considered as a potential evaluation criterion, formal invariance testing (e.g., multi-group CFA across gender or institutional subgroups) was not conducted due to sample size and design limitations. Consequently, conclusions regarding measurement invariance are beyond the scope of this study.

Findings and Results

The results of the confirmatory factor analysis (CFA) for the campus climate measurement model are presented in Table 1. Overall, the CFA results indicate that the proposed measurement model provides an acceptable, though not optimal, fit to the data. The global chi-square test was statistically significant ($\chi^2 = 434.904$, $df = 156$, $p < .001$), indicating a lack of perfect model fit. However, given the chi-square statistic's sensitivity to sample size, additional fit indices were considered to assess overall model adequacy.

Table 1

Overall Model Fit Test

Fit Index	Value	Cut-off Value	Model Fit to Data
Chi-Square	434,904	-	-
Df	156	-	-
Significance Probability	0.000	> 0.05	No
CMIN/DF	2.788	< 5	Yes
RMSEA	0.095	< 0.1	Yes
TLI	0.915	> 0.9	Yes
CFI	0.915	> 0.9	Yes
IFI	0.930	> 0.9	Yes
RMR	0.069	< 0.1	Yes
AGFI	0.821	0.8 < AGFI < 0.9	Yes (Marginal Fit)
GFI	0.873	0.8 < GFI < 0.9	Ya (Margina Fit)

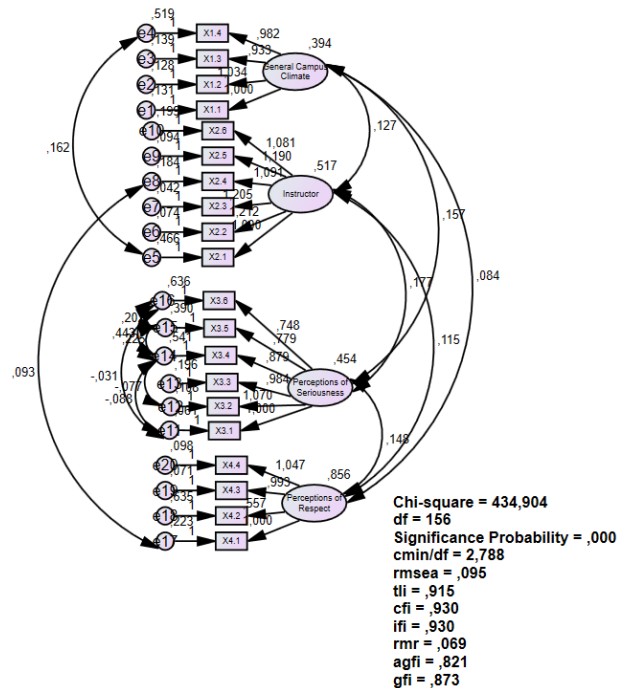

Figure 1

Overall Model Fit Test Results

Several relative and incremental fit indices met commonly accepted criteria. The CMIN/DF value was 2.788, which falls below the recommended threshold of 5.00, indicating an acceptable level of model parsimony. The Tucker–Lewis Index (TLI = 0.915), Comparative Fit Index (CFI = 0.915), and Incremental Fit Index (IFI = 0.930) all exceeded the conventional cut-off value of 0.90, suggesting adequate comparative fit. The Root Mean Square Residual (RMR = 0.069) also met the recommended criterion of less than 0.10.

In contrast, the Root Mean Square Error of Approximation (RMSEA = 0.095) indicates a borderline level of fit. Although this value falls below the more lenient cut-off of 0.10, it exceeds the stricter criteria often recommended in psychometric literature (e.g., RMSEA < 0.08 for acceptable fit and < 0.06 for good fit). In addition, the absolute fit indices GFI (0.873) and AGFI (0.821) fall within the range commonly interpreted as marginal fit. Taken together, these results suggest that the measurement model provides an acceptable but

marginal representation of the data, rather than a clearly optimal fit.

The overall CFA model, including standardized factor loadings for each item, is illustrated in Figure 1. All standardized factor loadings exceeded the minimum threshold of 0.50, indicating that each item contributed meaningfully to its intended latent factor. However, the strength of the loadings varied across items, suggesting differences in indicator quality within factors. For transparency and to allow detailed evaluation of item performance, standardized factor loadings are reported in the model diagram rather than summarized only as threshold-based statements.

Following the evaluation of model fit, reliability and convergent validity were examined using Construct Reliability (Crane et al., 2012) and Average Variance Extracted (Chirkina & Khavenson), as recommended for CFA-based measurement models (Fornell & Larcker, 1981; Hair et al., 2013). The results of the CR and AVE calculations for each first-order factor are presented in Table 2.

Table 2*Results of the Calculation of Average Variance Extracted and Construct Reliability*

	Average Variance Extracted	Construct Reliability
General Campus Climate	0,743	0,920
Instructor	0,819	0,964
Perceptions of Seriousness	0,644	0,912
Perceptions of Respect	0,740	0,916

All four factors, General Campus Climate, Instructor, Perceptions of Seriousness, and Perceptions of Respect, demonstrated CR values above the recommended threshold of 0.70, indicating adequate internal consistency. Similarly, all AVE values exceeded 0.50, suggesting that their respective latent constructs explained a substantial proportion of variance in the indicators. These findings provide support for convergent validity at the factor level.

It should be noted that although the GCC is theoretically described as comprising two broader dimensions, General Campus Climate and Academic Climate, the present analysis focused on first-order factors only. The relationships between these four factors and the two higher-order dimensions were not explicitly modeled through a second-order CFA. Therefore, conclusions regarding the hierarchical structure of the GCC should be interpreted with caution.

The evidence for validity presented in this study is limited to convergent validity, assessed using factor loadings, CR, and AVE. Discriminant validity among the four factors was not formally evaluated using established criteria such as the Fornell–Larcker criterion or the heterotrait–monotrait ratio (HTMT). Consequently, the degree to which the factors are empirically distinct from one another cannot be fully determined based on the current results.

In addition, although internal consistency was assessed using CR, Cronbach's alpha coefficients were not calculated or reported. Therefore, statements regarding reliability are based solely on CR estimates rather than multiple reliability indices. Finally, no criterion-related validity evidence (e.g., correlations with academic satisfaction or student stress) is reported in this study, nor are such analyses presented in the Results section. As a result, claims regarding relationships between campus climate and external

variables are beyond the scope of the present findings and should be addressed in future research.

Discussion and Conclusion

The present study aimed to adapt the General Campus Climate Scale (GCC) developed by Reid & Radhakrishnan (2003) to the Indonesian higher education context and to examine its factorial structure and internal consistency. Overall, the findings provide preliminary empirical support for the use of the GCC in this context, while also revealing several limitations to consider when interpreting the results. Rather than demonstrating a definitive validation of the instrument, this study should be viewed as an initial step toward establishing the psychometric adequacy of the GCC for Indonesian university students.

The confirmatory factor analysis results indicated that the proposed measurement model had an acceptable, though not optimal, fit to the data. Although several incremental fit indices, such as the CFI, TLI, and IFI, exceeded conventional thresholds, the significant chi-square statistic and the borderline RMSEA value suggest that the model does not fully reproduce the observed covariance matrix. This pattern of results is not uncommon in applied CFA studies, particularly when sample sizes are moderate and models involve multiple indicators. Nonetheless, these findings indicate that some degree of model misfit remains and should not be overlooked. In the present study, modification indices were not used to introduce correlated error terms or cross-loadings, as the primary objective was to test the theoretical structure of the original GCC rather than to improve fit through data-driven model modification. Consequently, the results reflect a conservative test of the original measurement model.

At the item level, all indicators demonstrated standardized factor loadings above the minimum

recommended threshold, suggesting that each item contributed meaningfully to its intended latent construct. However, the magnitude of factor loadings varied across items, indicating differences in indicator strength within factors. Such variation suggests that while the overall structure is supported, certain items may function as weaker indicators in the Indonesian context. Future research could explore item-level refinements, including rewording or removing less robust indicators, to enhance model fit and measurement precision.

Reliability analysis using construct reliability, as reported by Crane et al. (2012), showed that all first-order factors met acceptable internal consistency criteria. These findings suggest that the adapted GCC demonstrates adequate internal coherence within each factor. However, the evidence of reliability in this study was limited to CR estimates, as Cronbach's alpha coefficients were neither calculated nor reported. While CR is widely accepted within the CFA framework, reporting multiple reliability indices would strengthen confidence in the instrument's stability. Therefore, the reliability findings should be interpreted as supportive but preliminary.

With respect to validity, the present study provides evidence only for convergent validity at the factor level, as indicated by satisfactory CR and AVE values. Discriminant validity among the four factors was not examined, and no formal tests were conducted to determine whether the constructs are empirically distinct. In addition, criterion-related validity was not assessed because no external variables, such as academic satisfaction or student stress, were included in the analysis. Although previous studies have demonstrated associations between campus climate and such outcomes, these relationships were not tested in the current study and therefore cannot be claimed as empirical findings.

The theoretical contribution of the GCC lies in its focus on students' subjective perceptions of interpersonal treatment, seriousness, and respect within the campus environment. The present findings suggest that these dimensions retain conceptual relevance in the Indonesian higher education context, at least within the sampled institutions. However, it is important to note that the sample was drawn exclusively from Muhammadiyah universities in East Java, which share

specific religious, organizational, and cultural characteristics. As a result, the observed factor structure may reflect contextual features unique to these institutions rather than the broader diversity of Indonesian higher education settings.

Furthermore, the study did not examine whether the measurement model functions equivalently across different student subgroups, such as gender, study program, year of study, or institutional type. Without subgroup analyses or formal measurement invariance testing, it cannot be assumed that the GCC operates uniformly across all Indonesian students. Therefore, generalizations to "Indonesian culture" as a whole should be made with caution, and the findings should be interpreted as context-specific rather than universally representative.

In conclusion, this study contributes to the literature by providing an initial examination of the General Campus Climate Scale in the Indonesian higher education context. The findings support the instrument's basic factorial structure and internal consistency, while also highlighting important areas for further development. Future research should involve more diverse and representative samples, consider alternative response formats, test measurement invariance across subgroups, and examine discriminant and criterion-related validity. Through continued empirical refinement, the GCC has the potential to become a robust tool for assessing campus climate in Indonesian higher education.

This study aimed to adapt the General Campus Climate Scale (GCC) for use in the Indonesian higher education context and to provide an initial examination of its psychometric properties. Based on the results of the confirmatory factor analysis (CFA), the findings offer preliminary support for the factorial structure of the GCC, indicating that the scale reflects two theoretically proposed dimensions: general campus climate and academic climate. These results provide initial evidence of internal structure validity, although the overall model fit suggests that the measurement model represents the data at an acceptable but not optimal level.

The adapted GCC also demonstrated evidence of convergent validity and adequate internal consistency at the factor level, as indicated by satisfactory construct reliability and average variance extracted values. However, the evidence for reliability in this study was

limited to CFA-based estimates, and additional indices, such as test-retest reliability or alternative internal consistency measures, were not examined. Consequently, the psychometric findings should be interpreted as preliminary rather than conclusive.

Several limitations should be considered when interpreting the results. The sample was restricted to undergraduate students from Muhammadiyah universities in East Java, which share specific organizational and cultural characteristics. As a result, the generalizability of the findings to other types of higher education institutions or to Indonesian students more broadly is limited. Moreover, the study did not examine measurement invariance across subgroups or assess discriminant and criterion-related validity, which constrains the scope of conclusions that can be drawn regarding the scale's broader applicability.

Despite these limitations, the adapted GCC shows potential as a diagnostic instrument for examining students' perceptions of campus climate within similar institutional contexts. The scale may be useful for identifying areas of concern related to interpersonal treatment, perceived seriousness, and respect in academic settings, thereby informing institution-specific interventions. However, practical applications should be pursued cautiously and in conjunction with further empirical validation.

Future research is recommended to test the adapted GCC with larger, more diverse samples, including students from different types of institutions, regions, and levels of study. Subsequent studies should also examine measurement invariance, discriminant validity, and criterion-related validity, and consider alternative response formats. Through continued refinement and validation, the GCC may become a more robust tool for assessing campus climate in Indonesian higher education.

Acknowledgments

The authors express their gratitude and appreciation to all participants.

Declaration of Interest

The authors of this article declared no conflict of interest.

Ethical Considerations

The study protocol adhered to the principles outlined in the Declaration of Helsinki, which provides guidelines for ethical research involving human participants. Ethical considerations in this study were that participation was entirely optional.

Transparency of Data

In accordance with the principles of transparency and open research, we declare that all data and materials used in this study are available upon request.

Funding

This research was carried out independently, with personal funding and without financial support from any governmental or private institution or organization.

Authors' Contributions

All authors equally contribute to this study.

References

- Beasley, S. T., & McClain, S. (2021). Examining psychosociocultural influences as predictors of Black college students' academic self-concept and achievement. *Journal of Black Psychology*, 47(2-3), 118-150. <https://doi.org/10.1177/0095798420979794>
- Chirkina, T., & Khavenson, T. (2018). School climate: A history of the concept and approaches to defining and measuring it on PISA questionnaires. *Russian Education & Society*, 60(2), 133-160. <https://doi.org/10.1080/10609393.2018.1451189>
- Cohen, J. (2012). Creating a positive school climate: A foundation for resilience. In *Handbook of resilience in children* (pp. 411-423). Springer. https://doi.org/10.1007/978-1-4614-3661-4_24
- Commission, I. T. (2019). ITC guidelines for the large-scale assessment of linguistically and culturally diverse populations. *International Journal of Testing*, 19(4), 301-336. <https://doi.org/10.1080/15305058.2019.1631024>
- Crane, J. D., Ogborn, D. I., Cupido, C., Melov, S., Hubbard, A., Bourgeois, J. M., & Tarnopolsky, M. A. (2012). Massage therapy attenuates inflammatory signaling after exercise-induced muscle damage. *Science translational medicine*, 4(119), 119ra113-119ra113. <https://doi.org/10.1126/scitranslmed.3002882>
- DeWitt, P. M. (2017). *School climate: Leading with collective efficacy*. Corwin Press. <https://doi.org/10.4135/9781071873229>
- Fornell, C., & Larcker, D. F. (1981). Evaluating structural equation models with unobservable variables and measurement error. *Journal of Marketing Research*, 18(1), 39-50. <https://doi.org/10.2307/3151312>
- Gloria, A. M., & Kurpius, S. E. R. (1996). The validation of the cultural congruity scale and the university environment scale with Chicano/a students. *Hispanic Journal of Behavioral*

- Sciences*, 18(4), 533-549.
<https://doi.org/10.1177/07399863960184007>
- Hair, J. F., Black, W. C., Babin, B. J., & Anderson, R. E. (2013). *Multivariate data analysis: Pearson's new international edition PDF eBook*. Pearson Higher Ed.
<https://www.drnishikantjha.com/papersCollection/Multivariate%20Data%20Analysis.pdf>
- Maxwell, S., Reynolds, K. J., Lee, E., Subasic, E., & Bromhead, D. (2017). The impact of school climate and school identification on academic achievement: Multilevel modeling with student and teacher data. *Frontiers in psychology*, 8, 2069.
<https://doi.org/10.3389/fpsyg.2017.02069>
- Okendo, E. O., Nganzi, C., & Munyua, J. (2014). Relationships between school climate and students' academic achievement in KSCE examinations: A case of Kisii County, Kenya. *International Journal of Education Learning and Development*, 2(5), 7-17.
<https://ejournals.org/ijeld/vol-2issue5december-2014/relationships-school-climate-students-academic-achievement-ksce-examinations-case-kisii-county-kenya/>
- Reid, L. D., & Radhakrishnan, P. (2003). Race matters: the relation between race and general campus climate. *Cultural diversity and ethnic minority psychology*, 9(3), 263.
<https://doi.org/10.1037/1099-9809.9.3.263>
- Sury, M. (2016). *An Evaluation on Cultural Congruity to Promote Academic Success Among Latino/a College Students*, California State University, Northridge.
<https://scholarworks.calstate.edu/downloads/8p58ph22v>
- Thacker, E. J. (2007). *Diverse Students' Perceptions of Cultural Congruity and Environment at a University*.
<https://scholarsarchive.byu.edu/etd/1188/>
- Voight, A., & Nation, M. (2016). Practices for improving secondary school climate: A systematic review of the research literature. *American Journal of Community Psychology*, 58(1-2), 174-191. <https://doi.org/10.1002/ajcp.12074>
- Wang, M.-T., & Degol, J. L. (2016). School climate: A review of the construct, measurement, and impact on student outcomes. *Educational psychology review*, 28(2), 315-352.
<https://doi.org/10.1007/s10648-015-9319-1>